

**( ), \$'75 A '8 =G7 ' <5 B8 =B;**

@ C ? B ; ' 5 H H 9 9 8 ; 9 C : ' H 9 8 C C F Z 8 9 H 9 F A B 9 C B ' K < 7 <  
G 8 9 ' H 9 < 5 B 8 @ 9 C F ' C H 9 F ' C D 9 F 5 H C F ' G ' H C ' 6 9 ' B G 5 @ 9 8 "

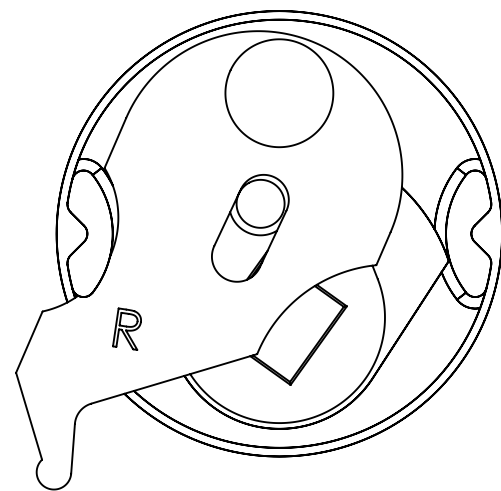

Hk'975A '8-G7 'A I GH69  
<5B898 '5GG<CK B"



CB 'Hk-GG89

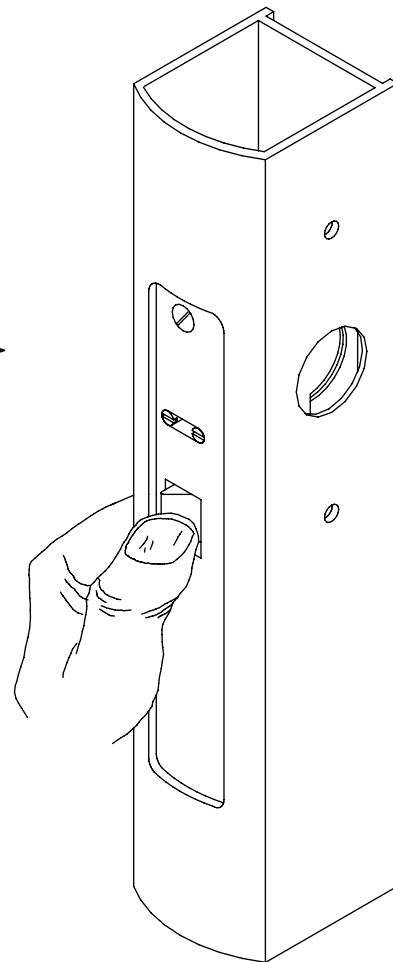

CB 'Hk-GG89

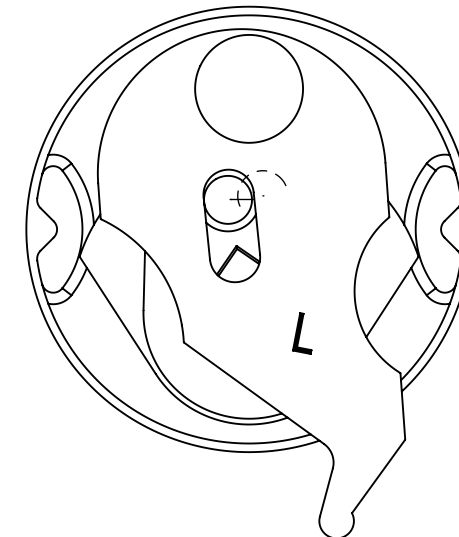

Hk'975A '8-G7 'A I GH69  
<5B898 '5GG<CK B"

**=BGHFI 7 H=CBG': CF'7 <5 B; =B; ' <5 B8 'C: '( ), \$'75 A '8 =G7**

**GH9D'**

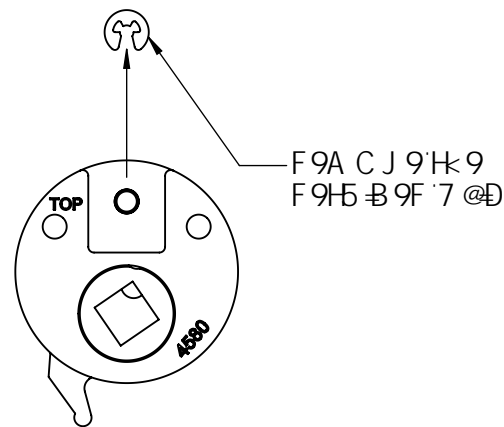

F9A C J 9 H 9  
F 9 H 5 B 9 F ' 7 @ D

**GH9D'&**

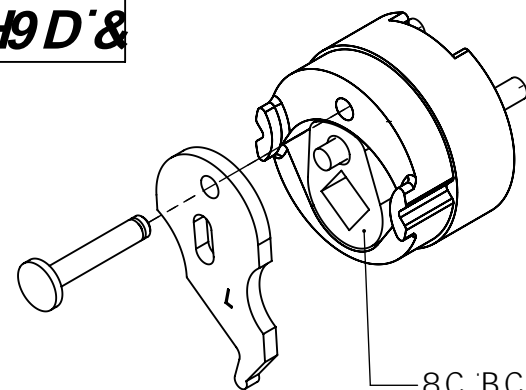

8C ' B C H F 9 A C J 9  
Hk'98F J 9 F ' D 9 7 9

DI @Hk'975A 'D J C H D B ' C I H  
C : ' Hk'975A '8-G7 '5GG<CK B"

**GH9D''**

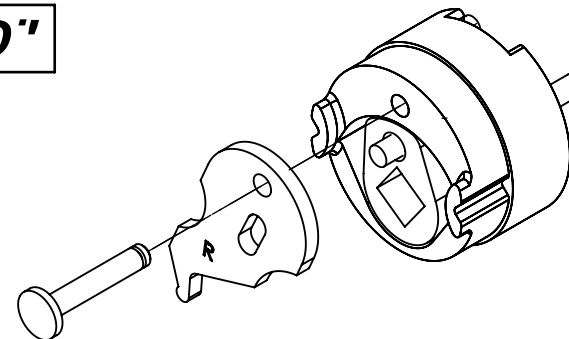

H FB 'Hk'975A 'C J 9 F '5B8 'D I G<  
Hk'975A 'D J C H D B 'Hk'F I 'Hk'9  
75A '5B8 'B H C 'Hk'975A '8-G7 '  
5GG<CK B"

**GH9D'()**

GB5D'Hk'9F9H5-B9F'7 @D  
BHC 'Hk'9: FCCJ9CB'Hk'9  
75A 'D J C H D B"

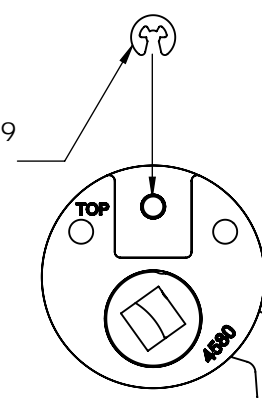

**DF9D5F5HC B**

I B @GGC H 9FK 69GD97 ÷ 98 5 @8 A 9BG C BG5F9 B A @A 9HFG  
 BC H9 H 9G9 8 A 9BG C B 5B8 H9A D @H9G 5GG A 9  
 ..... 5 8CC F H 7 ? B9GC : ( " ) a a " : CF 8CC FGC :  
 ..... C H 9F H 7 ? B9GC 7 C B G @ H : 57 HCFM  
 BC H9 7 @ I " 89BC H9G J 9FH 5 @ 7 9BH9F @B 9 C : GF 7 9K H B  
 ..... ( " a C : 8958 @H 7 < 7 9BH9F @B 9 "

**GF 7 9 B G H 5 @ 5 H C B**

% " B G H 5 @ 7 5 G H G F 7 9 7 I D K H : % ! ' & : @ H < 9 5 8 G 7 F 9 K G  
 & " B G H 5 @ G F 7 9 D @ H 9 K H : % ! ' & : @ H < 9 5 8 G 7 F 9 G  
 ..... B C H 9 : 6 C H : G F 7 9 7 I D 5 B 8 G F 7 9 D @ H 9 A I G H 6 9  
 ..... B G H 5 @ 9 8 D F C D 9 F @ M H C A 9 9 H 7 C 8 9 F 9 E I F 9 A 9 B H G

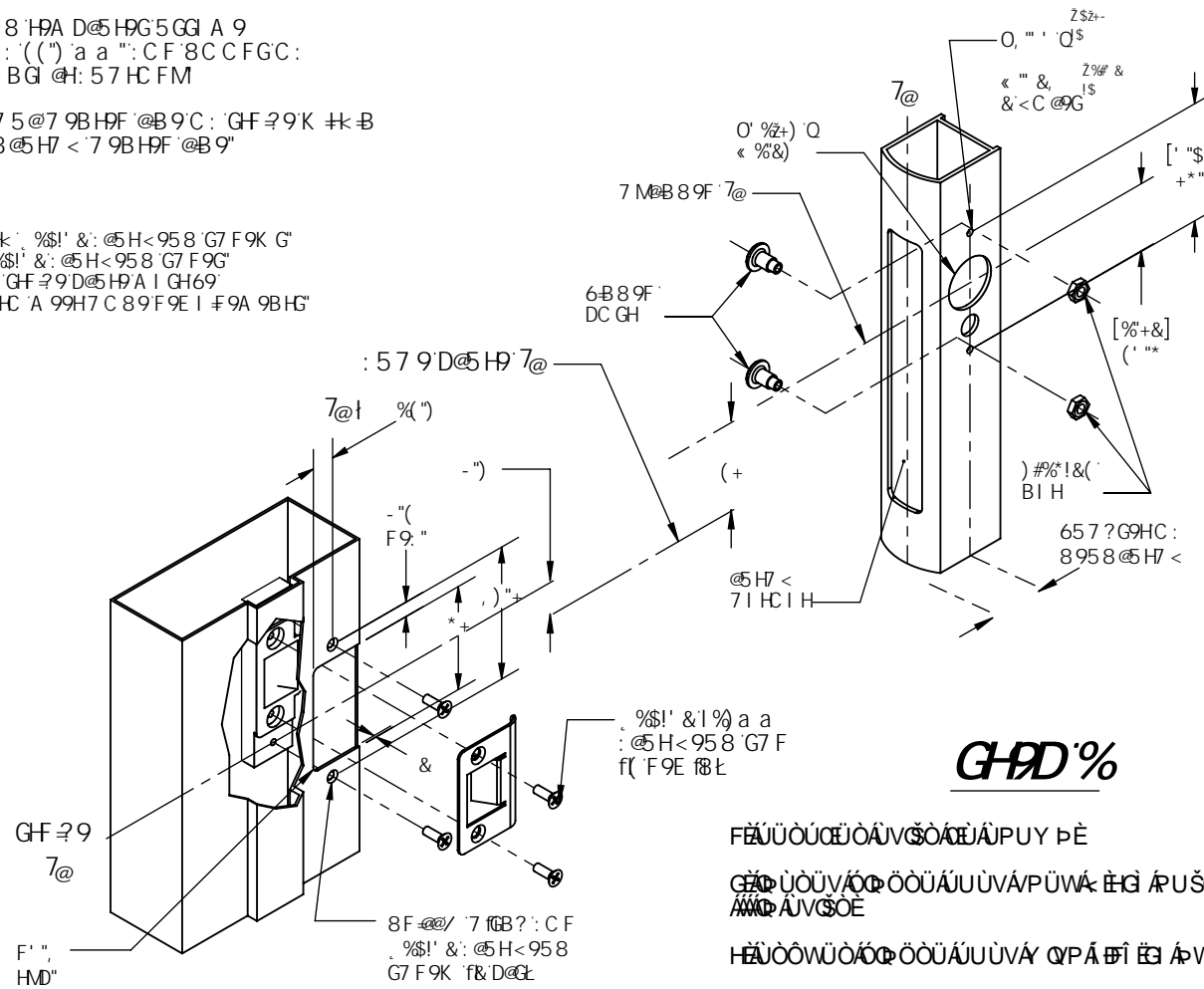

**GHD %**

F A U O O U O A U V S O A E U P U Y P E  
 G A U O O U V O O O U A U U V A P U W A E G I A P U S O A  
 H A U O O U O A U U A O C E A O W O P C E O P O D  
 H A U O O U O A U U A O C E A O W O P C E O P O D

**-BGH5 @ @ HCB**

**GHD &**

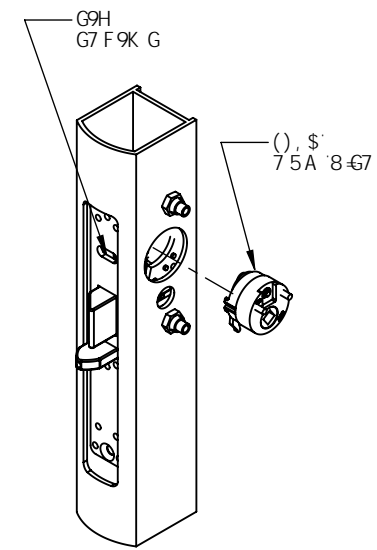

F A U O O U S A I E A U O O U A O O C E O S C V O P  
 H A U O O U A T U W P V O O A P U V U W O N O P U E  
 G A U O O U S A I I E A O C E A O W O P C E O P O D O S Y A  
 H A U O O U O A U U A O C E A O W O P C E O P O D  
 H A U O O U O A U U A O C E A O W O P C E O P O D

**GHD "**

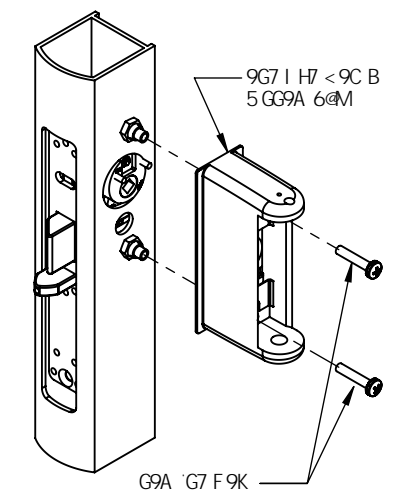

F A U O O U S A I O O S O A E U P U Y P E O S Y E  
 G A U O O U A T U W P V O O A P U V U W O N O P U E  
 H A U O O U O A U U A O C E A O W O P C E O P O D  
**A D C F H 5 B H**  
 V O P V O P A P O U O A U O O U Y U A U O O W O S Y E

**GHD (**

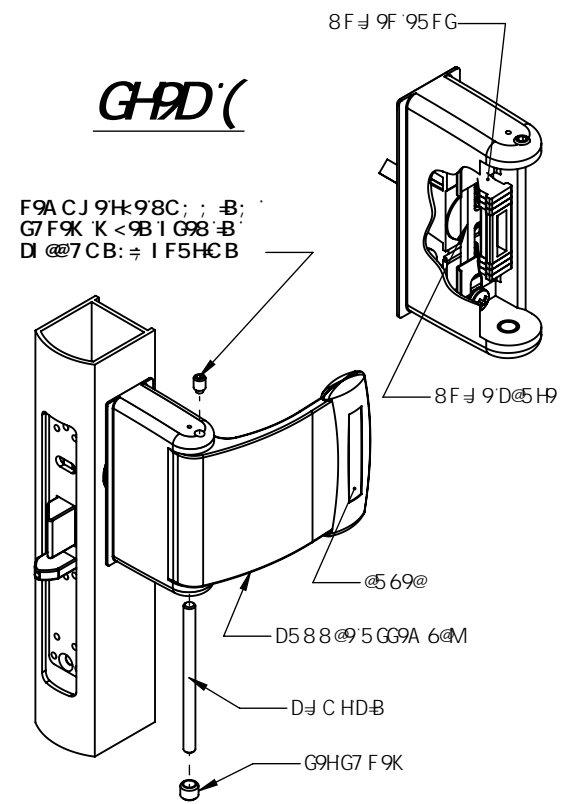

F 9 A C J 9 H 9 8 C : ; B ; G 7 F 9 K K < 9 B 1 G 9 8 B D I @ 7 C B : ÷ I F 5 H C B  
 F A U O O U S A I O O S O A E U P U Y P E O S Y E  
 H A U O O U O A U U A O C E A O W O P C E O P O D  
 G A U O O U S A I O O S O A E U P U Y P E  
 F A U O O U S A I O O S O A E U P U Y P E O S Y E  
 H A U O O U O A U U A O C E A O W O P C E O P O D  
 H A U O O U O A U U A O C E A O W O P C E O P O D

**-BGFI 7HC BG:CF 7 < 5B; B; < 5B8**

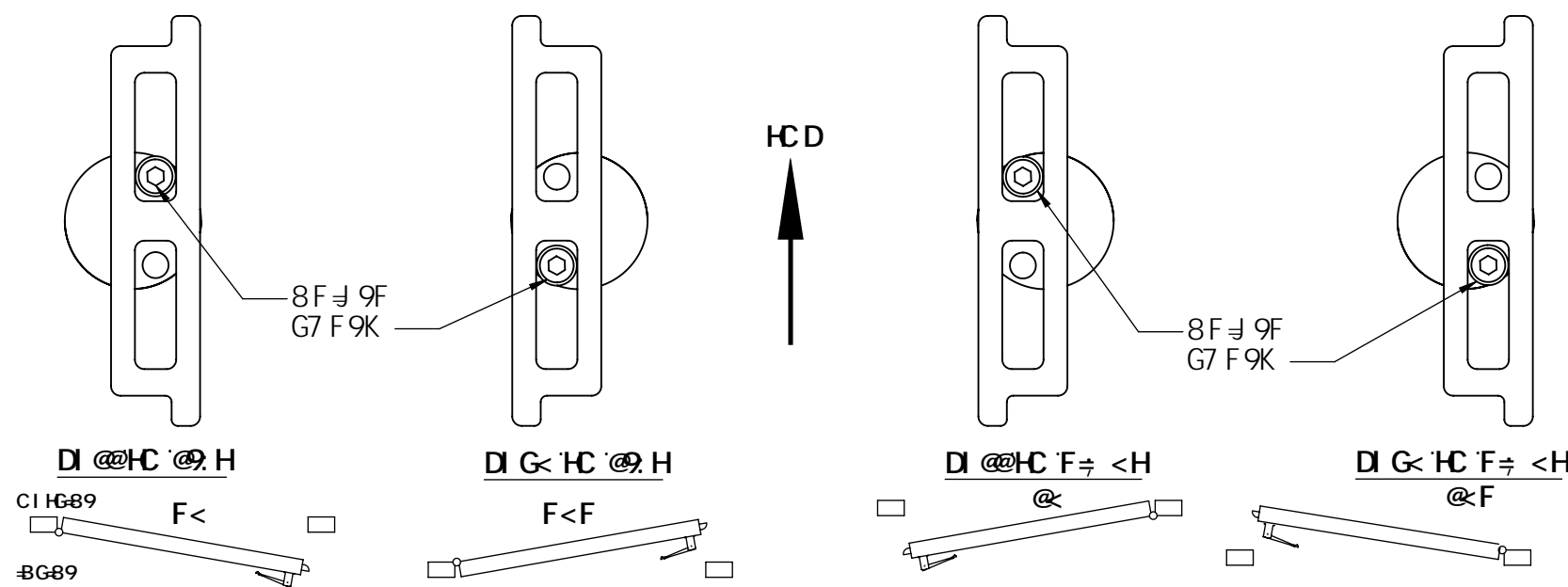

% " : B 8 ' 8 9 G F 9 8 ' 7 C B : ÷ I F 5 H C B "  
 & " F 9 A C J 9 ? 9 9 D 9 F G H C ' G 9 9 @ 7 5 H C B ' C : ' G D F B ; G  
 " / ' 8 F 9 F ' D @ H 9 "  
 ' " F 9 J 9 F G 9 G D F B ; G / ' 8 F 9 F ' D @ H 9 " ÷ B 9 7 9 G G 5 F M  
 ( " F 9 A C J 9 8 F 9 F ' G 7 F 9 K ' ÷ B 9 7 9 G G 5 F M 5 B 8 ' D @ 7 9  
 " B ' 8 9 G F 9 8 ' @ 7 5 H C B "  
 ) " F 9 D @ 7 9 ? 9 9 D 9 F G "  
 \* " 7 C B : ÷ I F 9 7 5 A ' 8 6 7 " F G 9 9 F 9 J 9 F G 9 L

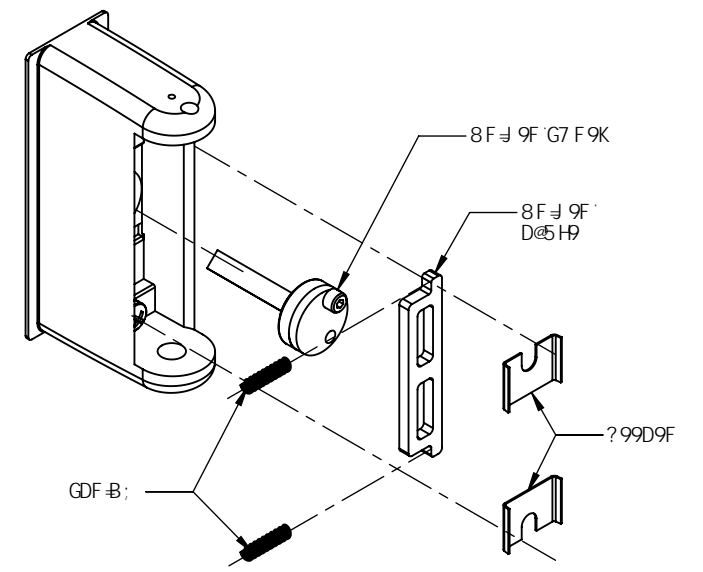

**Adams Rite**  
 ASSA ABLOY  
 5XUa gFjH9i fcdY @H  
 H YAYUXckgz7 UbbcW FcUXz  
 K c j Y l Ua fcb  
 K J % \$ F F F  
 ž ( ( 7 6 L ) ( , + ( ' ,

67; 3'RCF F NG'QRGTC VQT  
 : 2/23: 2/463

Tgx0 D08  
 GEP <33639

**CE** 7 9FH ÷ 7 5H9C : 7 CB: CFA #M  
 ..... Bc " % & % 7 D8! 5 66\$ %  
 F cvg < 2: 13412;

**KP UVCNNC VKQP "RP UVT WE VKQP U**  
 Rci g " 4 " qh 4  
 Crrxf <  
 F cvg <